

### Features

- Floating channel designed for bootstrap operation
- Fully operational to +600 V
- Tolerant to negative transient voltage, dV/dt immune
- Low VCC operation
- Gate drive supply range from 6.8 V to 20 V
- Undervoltage lockout for both channels
- 3.3V and 5V input logic compatible
- Matched propagation delay for both channels
- Logic and power ground +/- 5 V offset
- Lower di/dt gate driver for better noise immunity
- Output source/sink current capability 4.0 A (Typ.)
- Leadfree, RoHS compliant

### Applications

- Battery powered equipment
- Hand-tools
- Fork-lifts
- Golf-carts
- RC Hobby Equipment
- E-bike

### Product Summary

Topology	Single-Phase
$V_{\text{OFFSET}}$	$\leq 600 \text{ V}$
$V_{\text{OUT}}$	6.8 V – 20 V
$I_{\text{o+}}$ & $I_{\text{o-}}$ (typical)	4.0 A & 4.0 A
$t_{\text{on}}$ & $t_{\text{off}}$ (typical)	170 ns & 170 ns

### Package Options

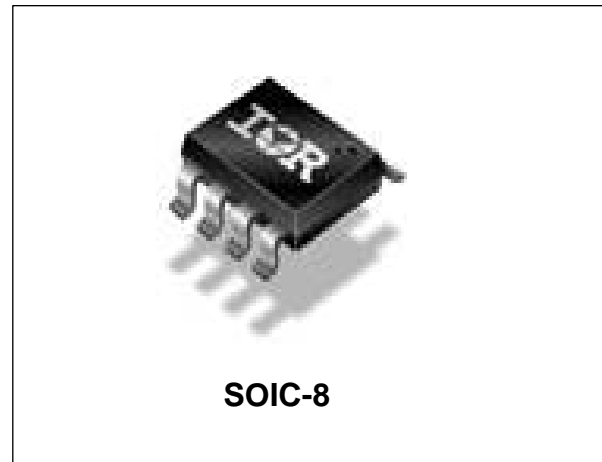

### Typical Connection Diagram

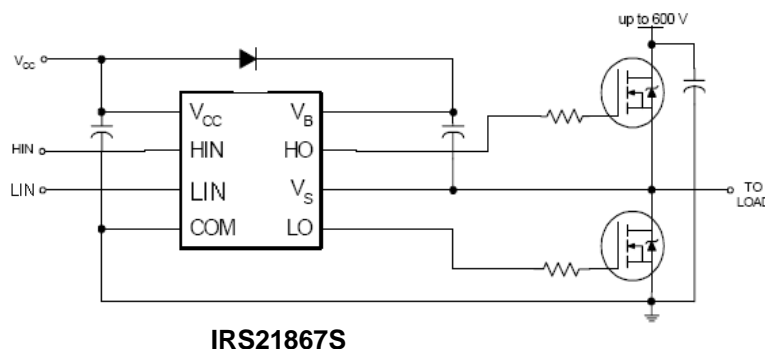

Refer to Lead Assignment for correct pin Configuration. This diagrams show electrical Connections only. Please refer to our Application Notes and Design Tips for proper circuit board layout

<b>Table of Contents</b>	<b>Page</b>
Typical Connection Diagram	1
Description/Feature Comparison	3
Qualification Information	3
Absolute Maximum Ratings	4
Recommended Operating Conditions	4
Dynamic Electrical Characteristics	5
Static Electrical Characteristics	5
Functional Block Diagram	6
Input/Output Pin Equivalent Circuit Diagram	7
Lead Definitions	8
Lead Assignments	8
Application Information and Additional Details	9
Package Details	17
Tape and Reel Details	18
Part Marking Information	19
Ordering Information	20

**Description**

The IRS21867 is a high voltage, high speed power MOSFET and IGBT driver with independent high and low side referenced output channels. Proprietary HVIC and latch immune CMOS technologies enable ruggedized monolithic construction. Low VCC operation allows use in battery powered applications. The logic input is compatible with standard CMOS or LSTTL output, down to 3.3 V logic. The output drivers feature a high pulse current buffer stage designed for minimum driver cross-conduction. The floating channel can be used to drive an N-channel power MOSFET or IGBT in the high-side configuration which operates up to 600V.

**Qualification Information<sup>†</sup>**

<b>Qualification Level</b>		Industrial <sup>††</sup>	
		Comments: This family of ICs has passed JEDEC's Industrial qualification. IR's Consumer qualification level is granted by extension of the higher Industrial level.	
<b>Moisture Sensitivity Level</b>		SOIC8N	MSL2 <sup>†††</sup> 260°C (per IPC/JEDEC J-STD-020)
<b>ESD</b>	Machine Model	Class A (per JEDEC standard JESD22-A115)	
	Human Body Model	Class 2 (per EIA/JEDEC standard EIA/JESD22-A114)	
<b>IC Latch-Up Test</b>		Class I, Level A (per JESD78)	
<b>RoHS Compliant</b>		Yes	

† Qualification standards can be found at International Rectifier's web site <http://www.irf.com/>

†† Higher qualification ratings may be available should the user have such requirements. Please contact your International Rectifier sales representative for further information.

††† Higher MSL ratings may be available for the specific package types listed here. Please contact your International Rectifier sales representative for further information.

### Absolute Maximum Ratings

Absolute Maximum Ratings indicate sustained limits beyond which damage to the device may occur. All voltage parameters are absolute voltages referenced to COM. The thermal resistance and power dissipation ratings are measured under board mounted and still air conditions.

Symbol	Definition	Min	Max	Units
$V_B$	High side floating absolute voltage	-0.3	625 (Note 1)	V
$V_S$	High side floating supply offset voltage	$V_B - 25$	$V_B + 0.3$	
$V_{HO}$	High side floating output voltage	$V_S - 0.3$	$V_B + 0.3$	
$V_{CC}$	Low side and logic fixed supply voltage	-0.3	25 (Note 1)	
$V_{LO}$	Low side output voltage	-0.3	$V_{CC} + 0.3$	
$V_{IN}$	Logic input voltage (HIN & LIN)	COM - 0.3	$V_{CC} + 0.3$	
$dV_S/dt$	Allowable offset supply voltage transient	—	50	V/ns
$P_D$	Package power dissipation @ $T_A \leq 25^\circ\text{C}$	—	0.625	W
$R_{thJA}$	Thermal resistance, junction to ambient	—	200	$^\circ\text{C}/\text{W}$
$T_J$	Junction temperature	—	150	$^\circ\text{C}$
$T_S$	Storage temperature	-50	150	
$T_L$	Lead temperature (soldering, 10 seconds)	—	300	

Note 1: All supplies are fully tested at 25V.

### Recommended Operating Conditions

For proper operation the device should be used within the recommended conditions. All voltage parameters are absolute voltages referenced to COM. The  $V_S$  offset rating is tested with all supplies biased at  $(V_{CC} - \text{COM}) = 15\text{V}$ .

Symbol	Definition	Min	Max	Units
$V_B$	High side floating supply absolute voltage	$V_S + 10$	$V_S + 20$	V
$V_S$	High side floating supply offset voltage	Note 2	600	
$V_{HO}$	High side floating output voltage	$V_S$	$V_B$	
$V_{CC}$	Low side and logic fixed supply voltage	6.8	20	
$V_{LO}$	Low side output voltage	0	$V_{CC}$	
$V_{IN}$	Logic input voltage (HIN & LIN)	COM	$V_{CC}$	
$T_A$	Ambient temperature	-40	125	$^\circ\text{C}$

† Note 2: Logic operational for  $V_S$  of -5V to +600V. Logic state held for  $V_S$  of -5V to  $-V_{BS}$ . (Please refer to the Design Tip DT97-3 for more details).

**Dynamic Electrical Characteristics**

$V_{CC} = V_{BS} = 15V$ ,  $C_L = 1000$  pF,  $T_A = 25^\circ C$  unless otherwise specified.

Symbol	Definition	Min	Typ	Max	Units	Test Conditions
$t_{on}$	Turn-on propagation delay	—	170	250	ns	$V_S = 0V$
$t_{off}$	Turn-off propagation delay	—	170	250		$V_S = 0V$ or $600V$
MT	Delay matching $ t_{on} - t_{off} $	—	—	35		
$t_r$	Turn-on rise time	—	22	38		
$t_f$	Turn-off fall time	—	18	30		$V_S = 0V$

**Static Electrical Characteristics**

$V_{CC} = V_{BS} = 15V$ , and  $T_A = 25^\circ C$  unless otherwise specified. The  $V_{IN}$ , and  $I_{IN}$  parameters are referenced to COM and are applicable to the respective input leads: HIN, and LIN. The  $V_O$ , and  $I_O$  parameters are referenced to  $V_S/COM$  and are applicable to the respective output leads: HO and LO.

Symbol	Definition	Min	Typ	Max	Units	Test Conditions	
$V_{IH}$	Logic "1" input voltage for HO & LO	2.5	—	—	V	$V_{CC} = 10V$ to $20V$	
$V_{IL}$	Logic "0" input voltage for HO & LO	—	—	0.8			
$V_{OH}$	High level output voltage, $V_{CC}$ or $V_{BS} - V_O$	—	—	1.4			$I_O = 0mA$
$V_{OL}$	Low level output voltage, $V_O$	—	—	0.15			$I_O = 20mA$
$I_{LK}$	Offset supply leakage current	—	—	50	SA	$V_B = V_S = 600V$	
$I_{QBS}$	Quiescent $V_{BS}$ supply current	20	60	150		$V_{IN} = 0V$ or $5V$	
$I_{QCC}$	Quiescent $V_{CC}$ supply current	50	120	240		$HIN = LIN = 5V$	
$I_{IN+}$	Logic "1" input bias current	—	250	—		$HIN = LIN = 0V$	
$I_{IN-}$	Logic "0" input bias current	—	—	5.0			
$V_{CCUV+}$ $V_{BSUV+}$	$V_{CC}$ and $V_{BS}$ supply undervoltage positive going threshold	5.34	6	6.66	V		
$V_{CCUV-}$ $V_{BSUV-}$	$V_{CC}$ and $V_{BS}$ supply undervoltage negative going threshold	4.90	5.50	6.10			
$V_{CCUVH}$ $V_{BSUVH}$	$V_{CC}$ and $V_{BS}$ supply undervoltage Hysteresis		0.5				
$I_{O+}$	Output high short circuit pulsed current		4.0		A	$V_O = 0V$ , $PW \leq 10Ss$	
$I_{O-}$	Output low short circuit pulsed current		4.0			$V_O = 15V$ , $PW \leq 10Ss$	

**Functional Block Diagrams**

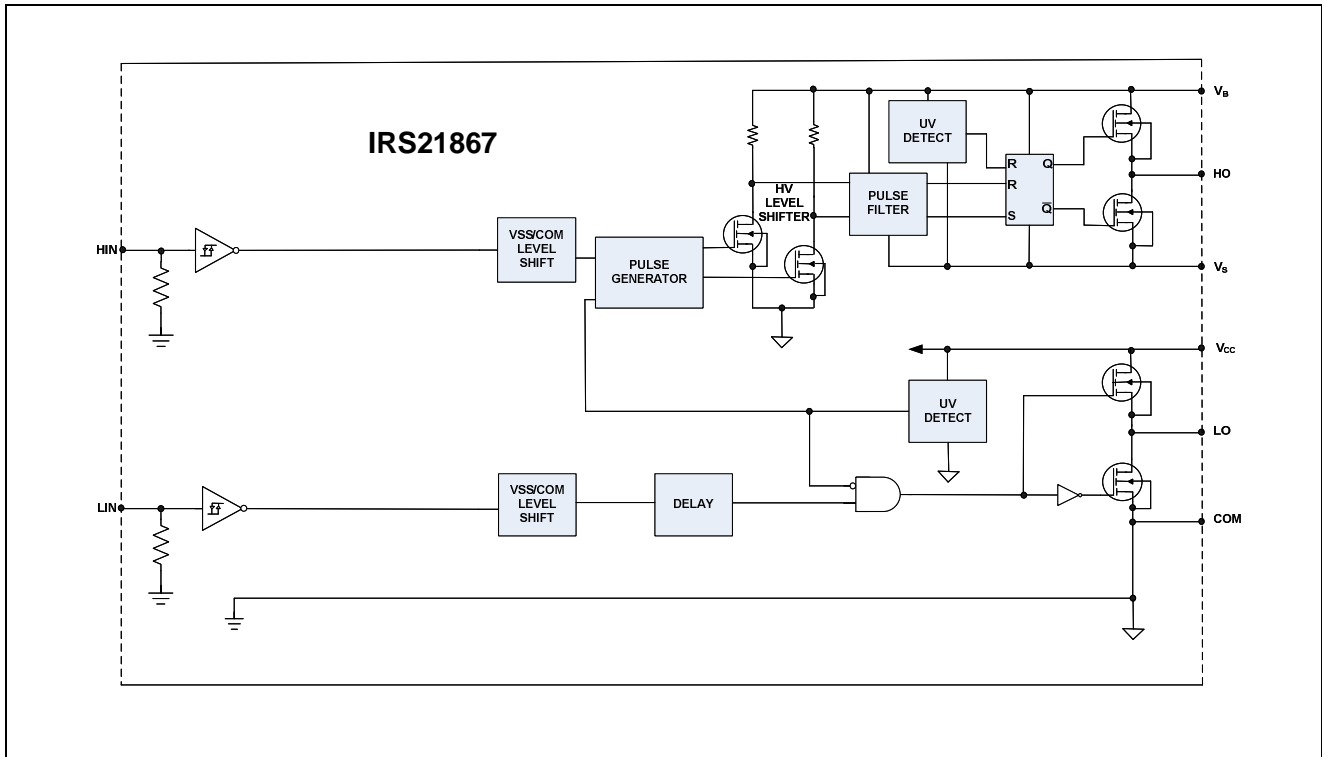

**Input/Output Pin Equivalent Circuit Diagrams**

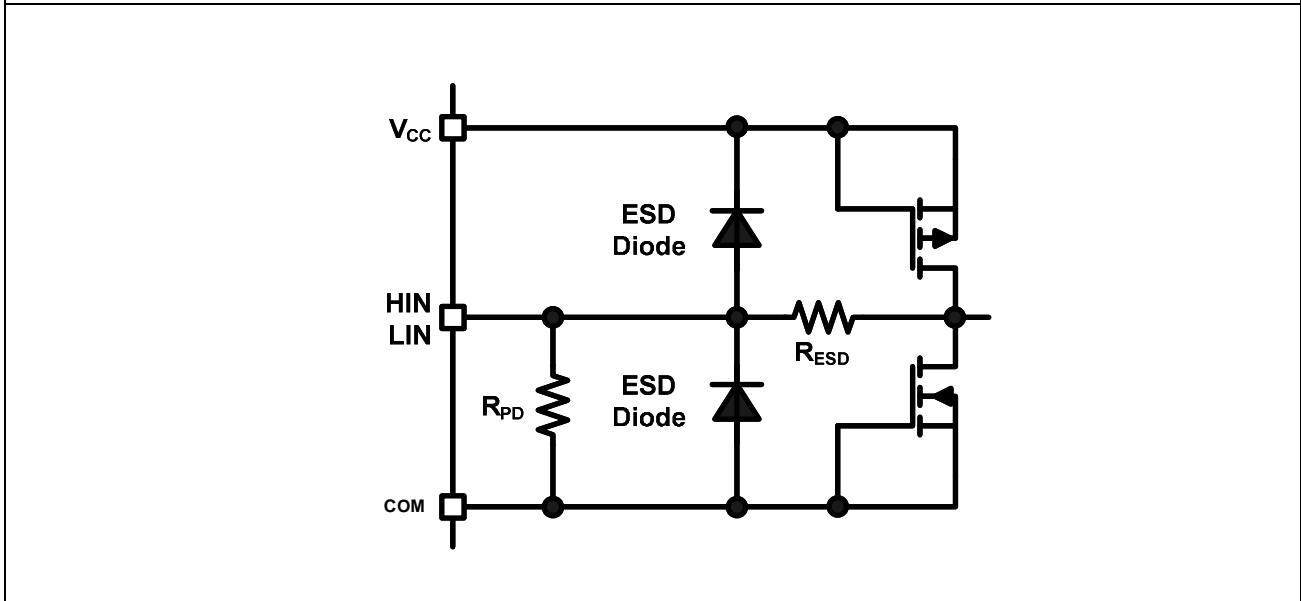
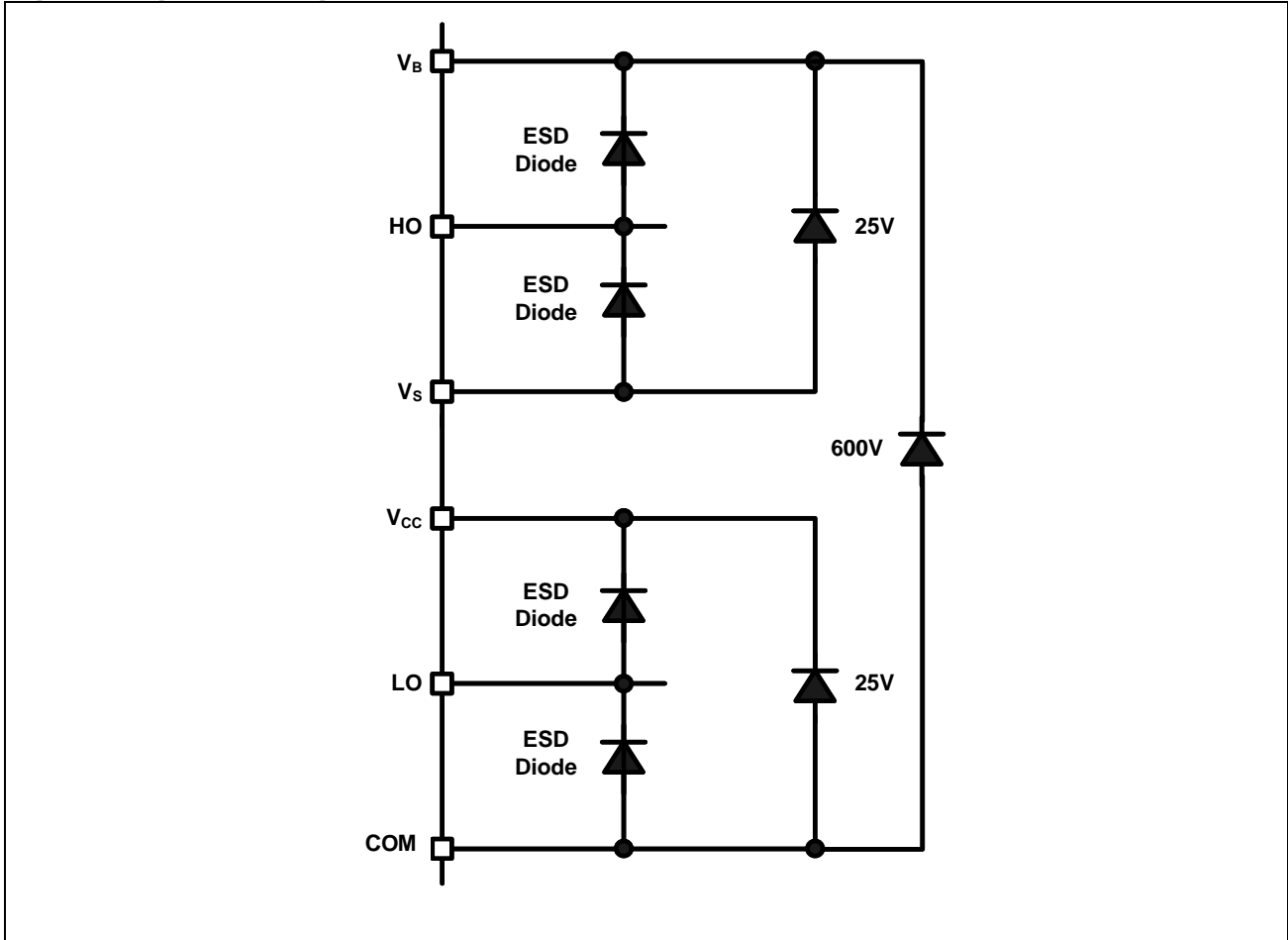

**Lead Definitions: IRS21867S**

Pin#	Symbol	Description
1	V <sub>CC</sub>	Low-side and logic fixed supply
2	HIN	Logic input for high-side gate driver output (HO), in phase with HO
3	LIN	Logic input for low-side gate driver output (LO), in phase with LO
4	COM	Low-side return
5	LO	Low-side gate drive output
6	V <sub>S</sub>	High-side floating supply return
7	HO	High-side gate drive output
8	V <sub>B</sub>	High-side floating supply

**Lead Assignments**

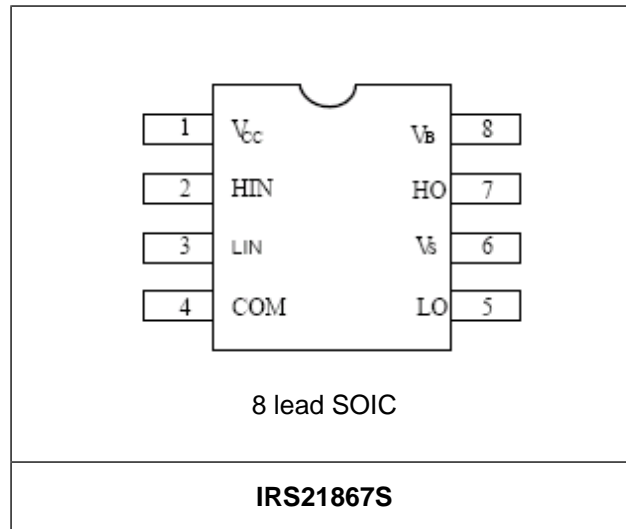



## Application Information and Additional Details

Informations regarding the following topics are included as subsections within this section of the datasheet.

- IGBT/MOSFET Gate Drive
- Switching and Timing Relationships
- Matched Propagation Delays
- Input Logic Compatibility
- Undervoltage Lockout Protection
- Negative  $V_s$  Transient SOA
- PCB Layout Tips
- Additional Documentation

### IGBT/MOSFET Gate Drive

The IRS21867 HVIC is designed to drive MOSFET or IGBT power devices. Figures 1 and 2 illustrate several parameters associated with the gate drive functionality of the HVIC. The output current of the HVIC, used to drive the gate of the power switch, is defined as  $I_O$ . The voltage that drives the gate of the external power switch is defined as  $V_{HO}$  for the high-side power switch and  $V_{LO}$  for the low-side power switch; this parameter is sometimes generically called  $V_{OUT}$  and in this case does not differentiate between the high-side or low-side output voltage.

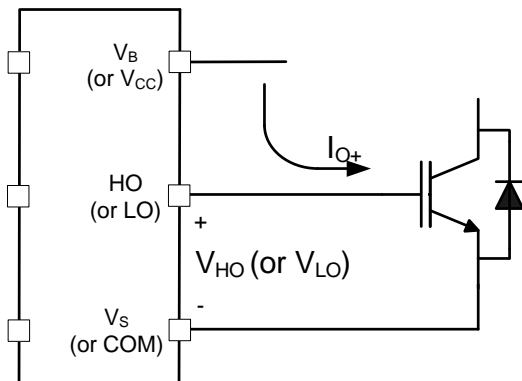

**Figure 1: HVIC sourcing current**

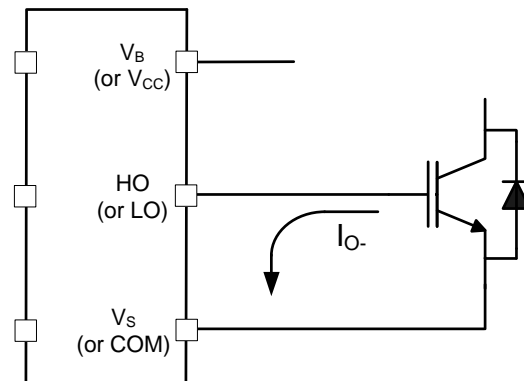

**Figure 2: HVIC sinking current**

**Switching and Timing Relationships**

The relationships between the input and output signals of the IRS21867 are illustrated below in Figures 3, 4. From these figures, we can see the definitions of several timing parameters (i.e.,  $PW_{IN}$ ,  $PW_{OUT}$ ,  $t_{ON}$ ,  $t_{OFF}$ ,  $t_R$ , and  $t_F$ ) associated with this device.

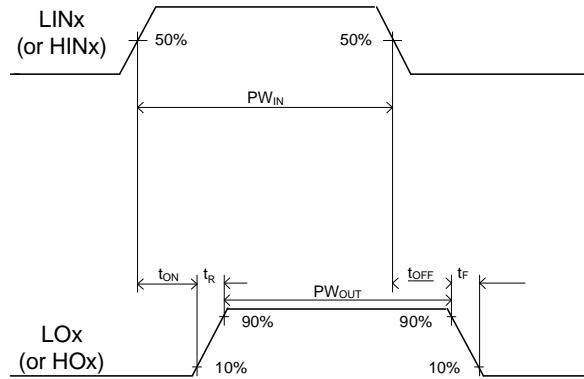

**Figure 3: Switching time waveforms**

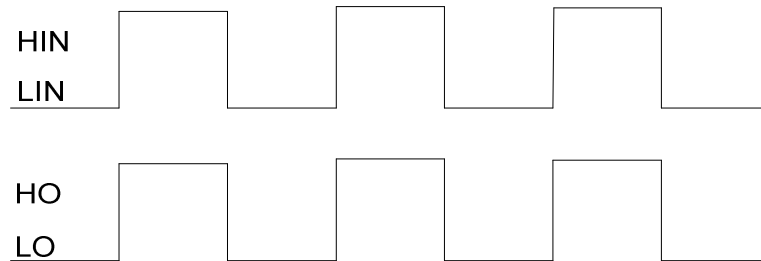

**Figure 4: Input/output timing diagram**

**Matched Propagation Delays**

The IRS21867 is designed with propagation delay matching circuitry. With this feature, the IC’s response at the output to a signal at the input requires approximately the same time duration (i.e.,  $t_{ON}$ ,  $t_{OFF}$ ) for both the low-side channels and the high-side channels; the maximum difference is specified by the delay matching parameter (MT). The propagation turn-on delay ( $t_{ON}$ ) is matched to the propagation turn-off delay ( $t_{OFF}$ ).

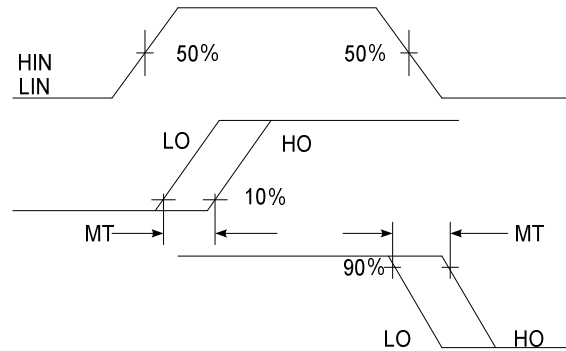

**Figure 5: Delay Matching Waveform Definition**

**Input Logic Compatibility**

The inputs of this IC are compatible with standard CMOS and TTL outputs. The IRS21867 has been designed to be compatible with 3.3 V and 5 V logic-level signals. Figure 8 illustrates an input signal to the IRS22867, its input threshold values, and the logic state of the IC as a result of the input signal.

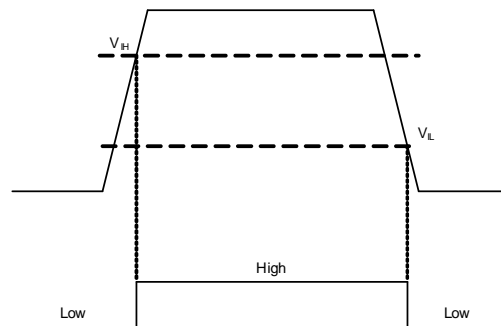

**Figure 6: HIN & LIN input thresholds**

**Undervoltage Lockout Protection**

This IC provides undervoltage lockout protection on both the  $V_{CC}$  (logic and low-side circuitry) power supply and the  $V_{BS}$  (high-side circuitry) power supply. Figure 7 is used to illustrate this concept;  $V_{CC}$  (or  $V_{BS}$ ) is plotted over time and as the waveform crosses the UVLO threshold ( $V_{CCUV+/-}$  or  $V_{BSUV+/-}$ ) the undervoltage protection is enabled or disabled.

Upon power-up, should the  $V_{CC}$  voltage fail to reach the  $V_{CCUV+}$  threshold, the IC will not turn-on. Additionally, if the  $V_{CC}$  voltage decreases below the  $V_{CCUV-}$  threshold during operation, the undervoltage lockout circuitry will recognize a fault condition and shutdown the high- and low-side gate drive outputs.

Upon power-up, should the  $V_{BS}$  voltage fail to reach the  $V_{BSUV}$  threshold, the IC will not turn-on. Additionally, if the  $V_{BS}$  voltage decreases below the  $V_{BSUV}$  threshold during operation, the undervoltage lockout circuitry will recognize a fault condition, and shutdown the high-side gate drive outputs of the IC.

The UVLO protection ensures that the IC drives the external power devices only when the gate supply voltage is sufficient to fully enhance the power devices. Without this feature, the gates of the external power switch could be driven with a low voltage, resulting in the power switch conducting current while the channel impedance is high; this could result in very high conduction losses within the power device and could lead to power device failure.

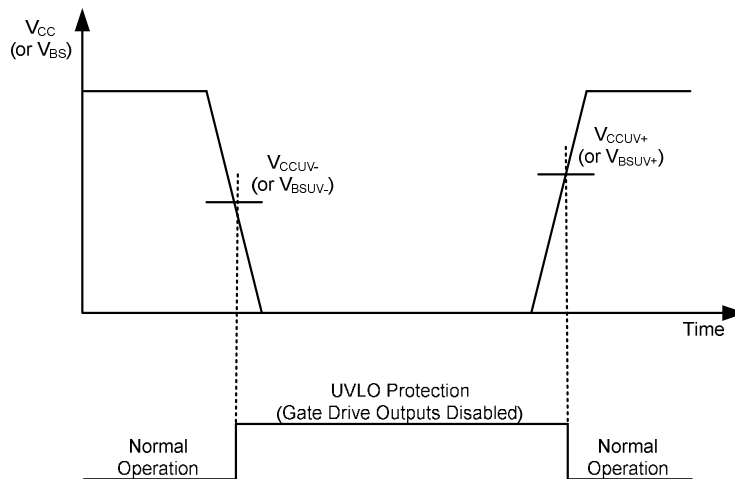
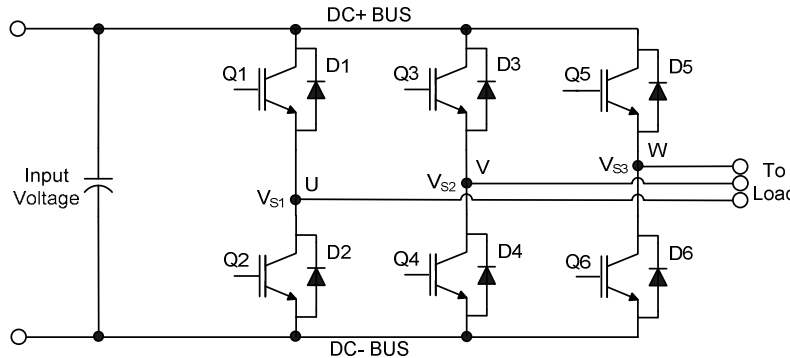

**Figure 7: UVLO protection**

**Tolerant to Negative  $V_s$  Transients**

A common problem in today's high-power switching converters is the transient response of the switch node's voltage as the power switches transition on and off quickly while carrying a large current. A typical 3-phase inverter circuit is shown in Figure 8; here we define the power switches and diodes of the inverter.

If the high-side switch (e.g., the IGBT Q1 in Figures 9 and 10) switches off, while the U phase current is flowing to an inductive load, a current commutation occurs from high-side switch (Q1) to the diode (D2) in parallel with the low-side switch of the same inverter leg. At the same instance, the voltage node  $V_{s1}$ , swings from the positive DC bus voltage to the negative DC bus voltage.



**Figure 8: Three phase inverter**

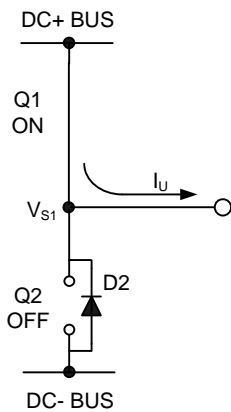

**Figure 9: Q1 conducting**

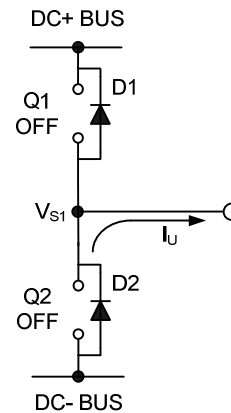

**Figure 10: D2 conducting**

Also when the V phase current flows from the inductive load back to the inverter (see Figures 11 and 12), and Q4 IGBT switches on, the current commutation occurs from D3 to Q4. At the same instance, the voltage node,  $V_{s2}$ , swings from the positive DC bus voltage to the negative DC bus voltage.

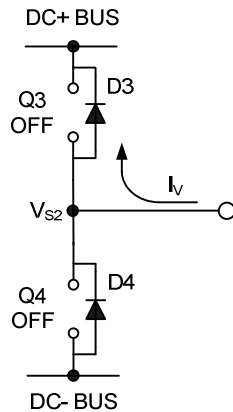

Figure 11: D3 conducting

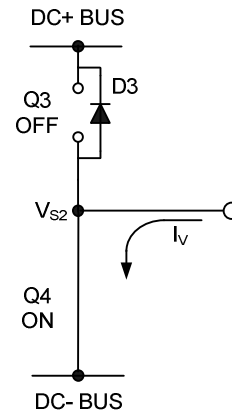

Figure 12: Q4 conducting

However, in a real inverter circuit, the  $V_S$  voltage swing does not stop at the level of the negative DC bus, rather it swings below the level of the negative DC bus. This undershoot voltage is called “negative  $V_S$  transient”.

The circuit shown in Figure 13 depicts one leg of the three phase inverter; Figures 14 and 15 show a simplified illustration of the commutation of the current between Q1 and D2. The parasitic inductances in the power circuit from the die bonding to the PCB tracks are lumped together in  $L_C$  and  $L_E$  for each IGBT. When the high-side switch is on,  $V_{S1}$  is below the DC+ voltage by the voltage drops associated with the power switch and the parasitic elements of the circuit. When the high-side power switch turns off, the load current momentarily flows in the low-side freewheeling diode due to the inductive load connected to  $V_{S1}$  (the load is not shown in these figures). This current flows from the DC- bus (which is connected to the COM pin of the HVIC) to the load and a negative voltage between  $V_{S1}$  and the DC- Bus is induced (i.e., the COM pin of the HVIC is at a higher potential than the  $V_S$  pin).

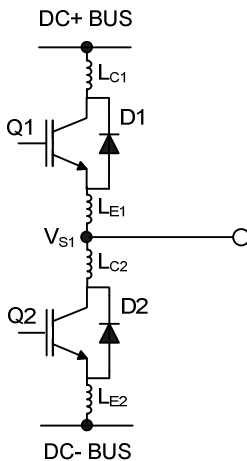

Figure 13: Parasitic Elements

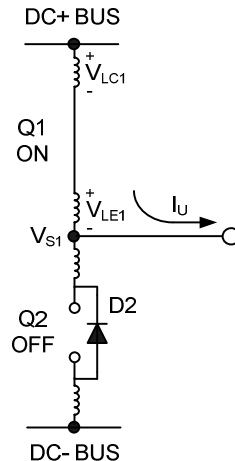

Figure 14:  $V_S$  positive

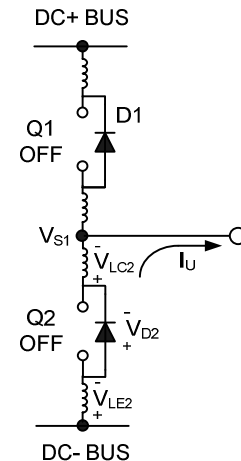
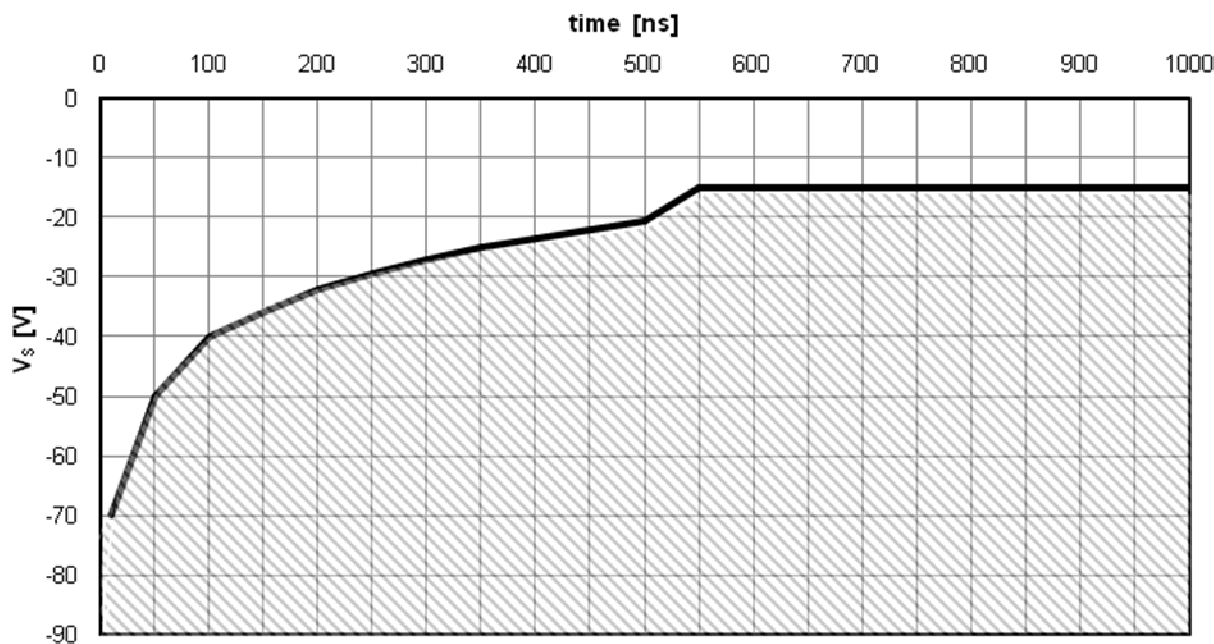

Figure 15:  $V_S$  negative

In a typical motor drive system,  $dV/dt$  is typically designed to be in the range of 3-5 V/ns. The negative  $V_S$  transient voltage can exceed this range during some events such as short circuit and over-current shutdown, when  $di/dt$  is greater than in normal operation.

International Rectifier’s HVICs have been designed for the robustness required in many of today’s demanding applications. An indication of the IRS21867’s robustness can be seen in Figure 16, where there is represented the IRS21867 Safe Operating Area at  $V_{BS}=15V$  based on repetitive negative  $V_S$  spikes. A negative  $V_S$  transient voltage falling in the grey area (outside SOA) may lead to IC permanent damage; viceversa unwanted functional anomalies or permanent damage to the IC do not appear if negative  $V_S$  transients fall inside SOA.



**Figure 16: Negative  $V_S$  transient SOA for IRS2607 @  $V_{BS}=15V$**

Even though the IRS21867 has been shown able to handle these large negative  $V_S$  transient conditions, it is highly recommended that the circuit designer always limit the negative  $V_S$  transients as much as possible by careful PCB layout and component use.

### PCB Layout Tips

Distance between high and low voltage components: Distance between high and low voltage components: It's strongly recommended to place the components tied to the floating voltage pins ( $V_B$  and  $V_S$ ) near the respective high voltage portions of the device. Please see the Case Outline information in this datasheet for the details.

**Ground Plane:** In order to minimize noise coupling, the ground plane should not be placed under or near the high voltage floating side.

**Gate Drive Loops:** Current loops behave like antennas and are able to receive and transmit EM noise (see Figure 17). In order to reduce the EM coupling and improve the power switch turn on/off performance, the gate drive loops must be reduced as much as possible. Moreover, current can be injected inside the gate drive loop via the IGBT collector-to-gate parasitic capacitance. The parasitic auto-inductance of the gate loop contributes to developing a voltage across the gate-emitter, thus increasing the possibility of a self turn-on effect.

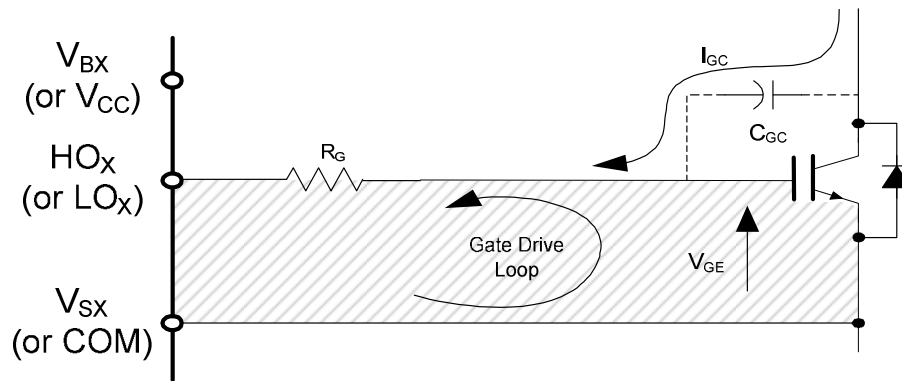

Figure 17: Antenna Loops

**Supply Capacitor:** It is recommended to place a bypass capacitor ( $C_{IN}$ ) between the  $V_{CC}$  and COM pins. A ceramic  $1\ \mu\text{F}$  ceramic capacitor is suitable for most applications. This component should be placed as close as possible to the pins in order to reduce parasitic elements.

**Routing and Placement:** Power stage PCB parasitic elements can contribute to large negative voltage transients at the switch node; it is recommended to limit the phase voltage negative transients. In order to avoid such conditions, it is recommended to 1) minimize the high-side emitter to low-side collector distance, and 2) minimize the low-side emitter to negative bus rail stray inductance. However, where negative  $V_S$  spikes remain excessive, further steps may be taken to reduce the spike. This includes placing a resistor (5  $\text{H}$  or less) between the  $V_S$  pin and the switch node (see Figure 18), and in some cases using a clamping diode between COM and  $V_S$  (see Figure 19). See DT04-4 at [www.irf.com](http://www.irf.com) for more detailed information.

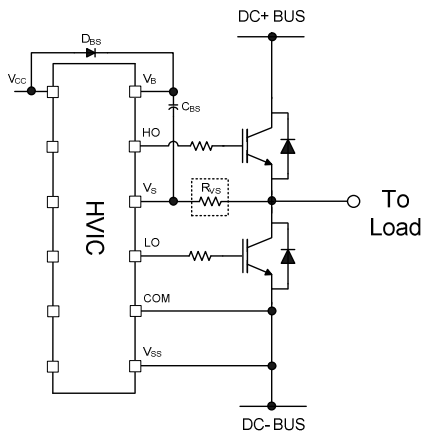

Figure 18:  $V_S$  resistor

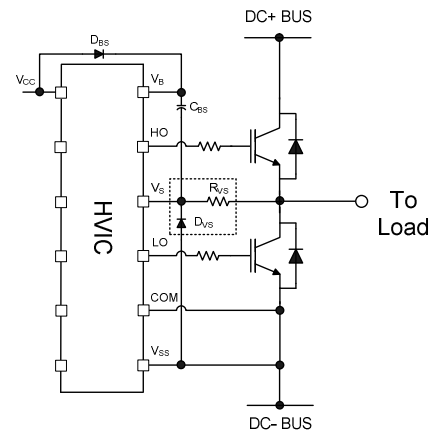

Figure 19:  $V_S$  clamping diode

### Additional Documentation

Several technical documents related to the use of HVICs are available at [www.irf.com](http://www.irf.com); use the Site Search function and the document number to quickly locate them. Below is a short list of some of these documents.

- DT97-3: Managing Transients in Control IC Driven Power Stages
- DT04-4: Using Monolithic High Voltage Gate Drivers
- AN-978: HV Floating MOS-Gate Driver ICs



**Package Details: SOIC8N**

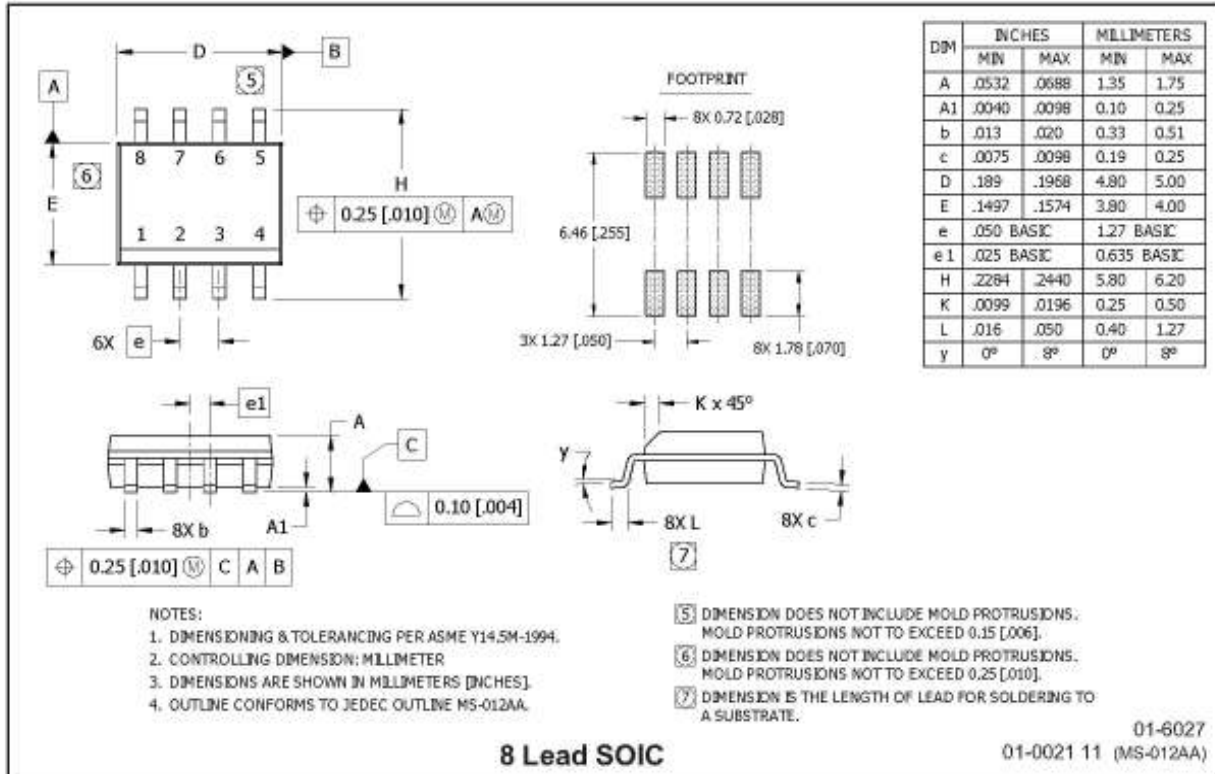

**Tape and Reel Details: SOIC8N**

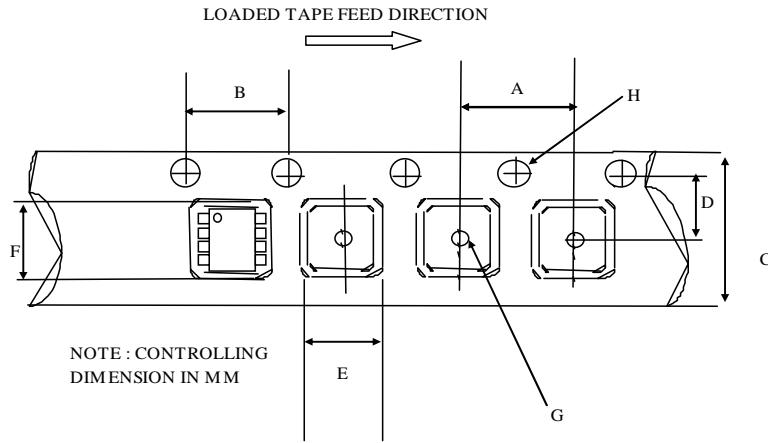

**CARRIER TAPE DIMENSION FOR 8SOICN**

Code	Metric		Imperial	
	Min	Max	Min	Max
A	7.90	8.10	0.311	0.318
B	3.90	4.10	0.153	0.161
C	11.70	12.30	0.46	0.484
D	5.45	5.55	0.214	0.218
E	6.30	6.50	0.248	0.255
F	5.10	5.30	0.200	0.208
G	1.50	n/a	0.059	n/a
H	1.50	1.60	0.059	0.062

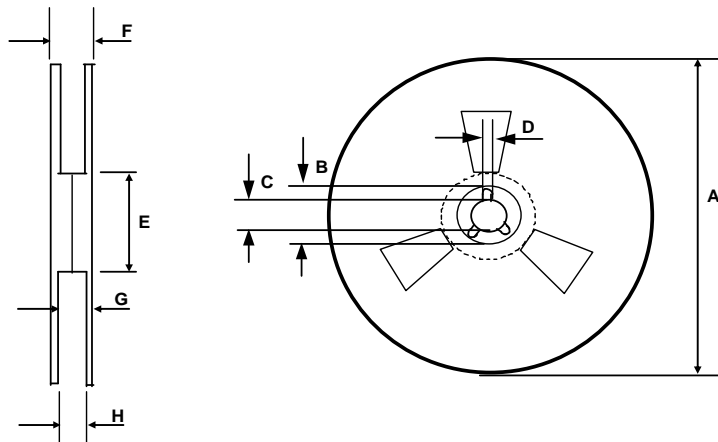

**REEL DIMENSIONS FOR 8SOICN**

Code	Metric		Imperial	
	Min	Max	Min	Max
A	329.60	330.25	12.976	13.001
B	20.95	21.45	0.824	0.844
C	12.80	13.20	0.503	0.519
D	1.95	2.45	0.767	0.096
E	98.00	102.00	3.858	4.015
F	n/a	18.40	n/a	0.724
G	14.50	17.10	0.570	0.673
H	12.40	14.40	0.488	0.566

**Part Marking Information**

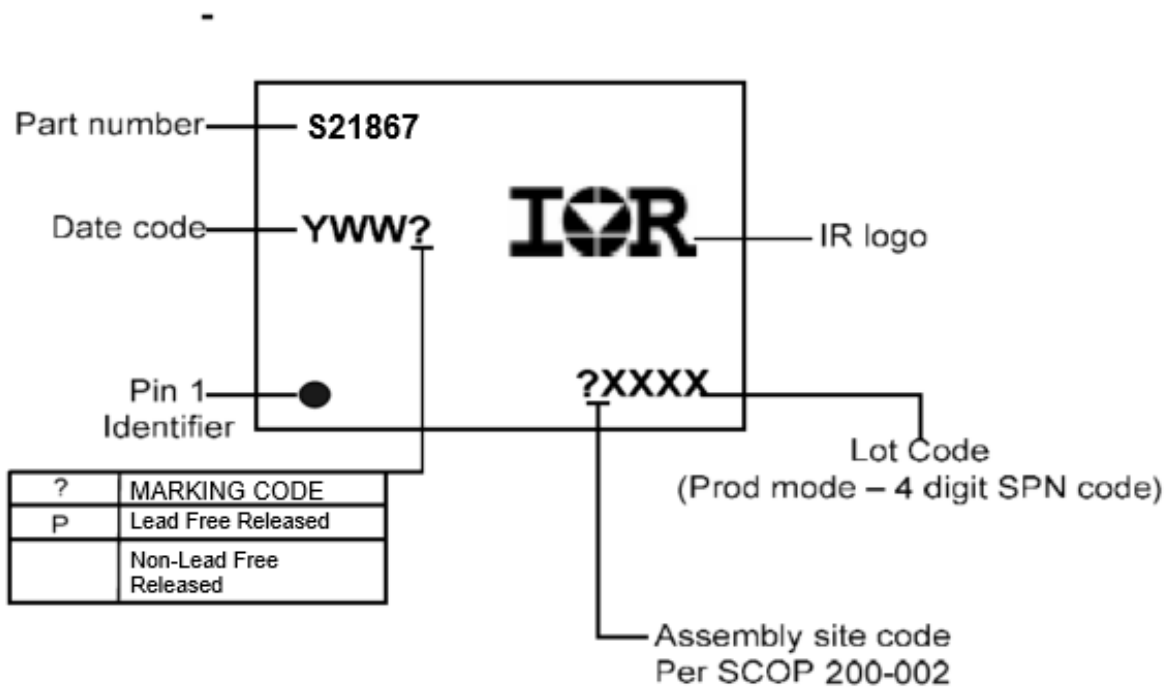

## Ordering Information

<b>P/n</b>	<b>Package</b>	<b>Packing</b>	<b>Pcs</b>
IRS21867SPbF	SOIC8	Tube	95
IRS21867STRPbF	SOIC8	Tape & Reel	2500

The information provided in this document is believed to be accurate and reliable. However, International Rectifier assumes no responsibility for the consequences of the use of this information. International Rectifier assumes no responsibility for any infringement of patents or of other rights of third parties which may result from the use of this information. No license is granted by implication or otherwise under any patent or patent rights of International Rectifier. The specifications mentioned in this document are subject to change without notice. This document supersedes and replaces all information previously supplied.

For technical support, please contact IR's Technical Assistance Center  
<http://www.irf.com/technical-info/>

**WORLD HEADQUARTERS:**  
 233 Kansas St., El Segundo, California 90245  
 Tel: (310) 252-7105

**Revision History**

Date	Comment
5/20/2010	Initial Draft
6/10/2010	Changed ABS MAX to 25V, Updated Iin+ to 250uA(Typ) to reflect 20kohm pull-down, Removed Min spec (2A) from Ilo+/Ilo-, Updated Block Diagram based on IRS2188 D/S
03/30/2011	Add recommended operation condition note
05/27/2011	Add ESD and Latch up specs
05/31/2011	Add application info and ordering info
11/11/2024	"Part Marking Information" figure updated