

η -Balance™ PWM Power Switch Fixed 50KHz Fsw

FEATURES

- ◆ Built-in 600V Power MOSFET
- ◆ Proprietary η -Balance™ Control to Boost Light Load Efficiency
- ◆ Proprietary “Zero OCP/OPP Recovery Gap” Control
- ◆ Fixed 50KHz Switching Frequency
- ◆ Built-in Soft Start Function
- ◆ Very Low Startup Current
- ◆ Frequency Reduction and Burst Mode Control for Energy Saving
- ◆ Current Mode Control
- ◆ Built-in Frequency Shuffling
- ◆ Built-in Synchronous Slope Compensation
- ◆ Cycle-by-Cycle Current Limiting
- ◆ Built-in Leading Edge Blanking (LEB)
- ◆ Constant Power Limiting
- ◆ Pins Floating Protection
- ◆ Audio Noise Free Operation
- ◆ VDD OVP & Clamp
- ◆ VDD Under Voltage Lockout (UVLO)

APPLICATIONS

Offline AC/DC Flyback Converter for

- ◆ AC/DC Adaptors
- ◆ Open-frame SMPS
- ◆ Set-Top Box Power Supplies
- ◆ ATX Standby Power

GENERAL DESCRIPTION

SF1539 is a high performance, high efficiency, highly integrated current mode PWM power switch for offline flyback converter applications.

In SF1539, PWM switching frequency with shuffling is fixed to 50KHz and is trimmed to tight range. When the output power demands decrease, the IC decreases switching frequency based on the proprietary η -Balance™ control to boost power conversion efficiency at the light load. When output power falls below a given value, the IC enters into burst mode and provides excellent efficiency without audio noise.

The IC can achieve “Zero OCP/OPP Recovery Gap” using SiFirst’s proprietary control algorithm. Meanwhile, the OCP/OPP variation versus universal line input is compensated.

The IC has built-in synchronized slope compensation to prevent sub-harmonic oscillation at high PWM duty output. The IC also has built-in soft start function to soften the stress on the MOSFET during power on period.

SF1539 integrates functions and protections of Under Voltage Lockout (UVLO), VCC Over Voltage Protection (OVP), Cycle-by-cycle Current Limiting (OCP), Pins Floating Protection, Over Load Protection (OLP), VCC Clamping, Leading Edge Blanking (LEB), etc.

SF1539 is available in DIP8 packages.

TYPICAL APPLICATION

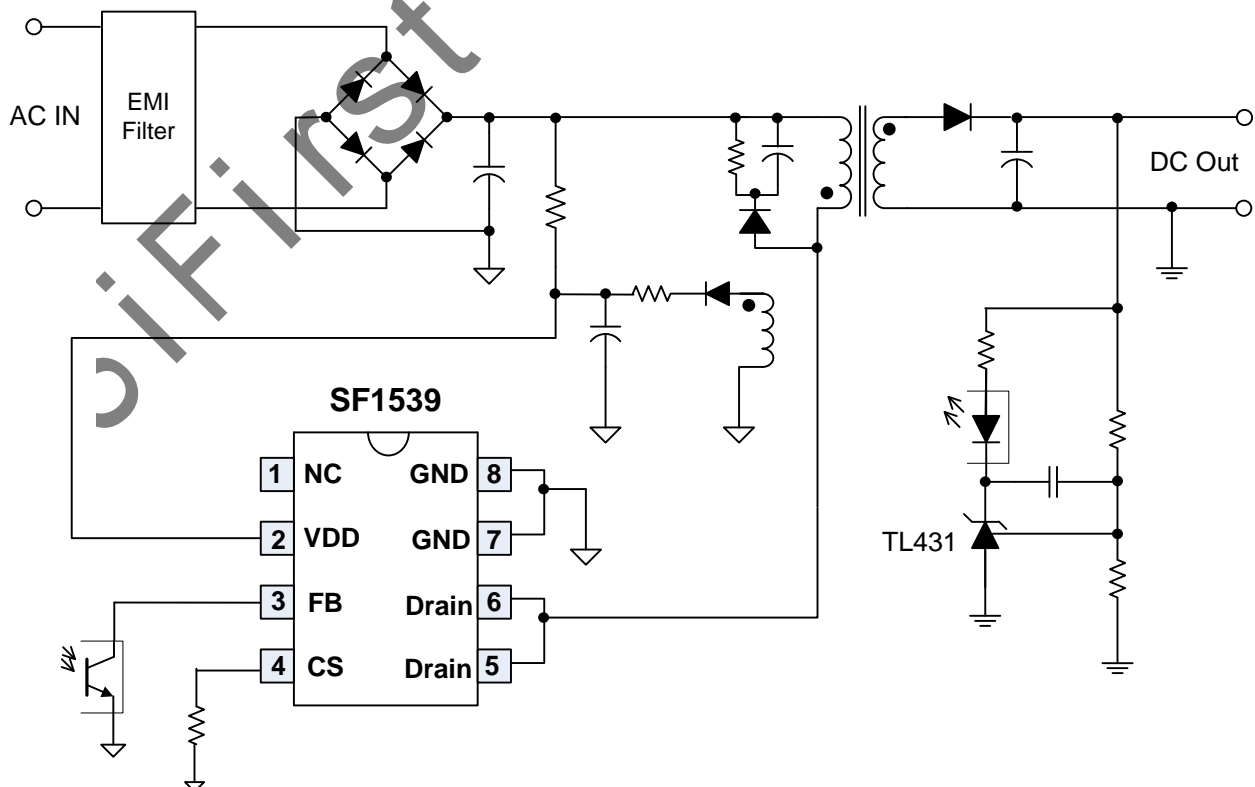

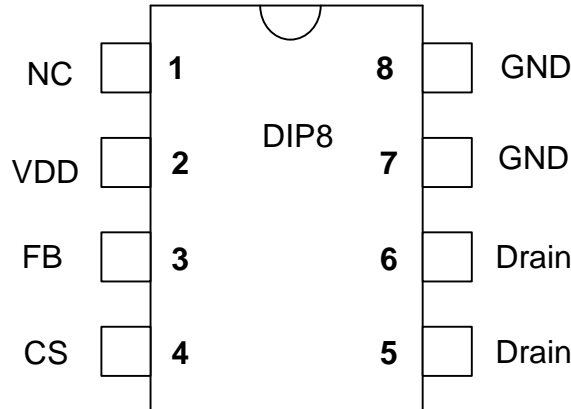
Pin Configuration

Ordering Information

Part Number	Top Mark	Package		Tape & Reel
SF1539DP	SF1539DP	DIP8	RoHs	

Output Power Table⁽¹⁾

Part Number	230VAC \pm 15% ⁽²⁾		85-265VAC	
	Adapter ⁽³⁾	Open Frame ⁽⁴⁾	Adapter ⁽³⁾	Open Frame ⁽⁴⁾
SF1539DP	18W	26W	13W	16W

Note 1. The Max. output power is limited by junction temperature

Note 2. 230VAC or 100/115VAC with doublers

Note 3. Typical continuous power in a non-ventilated enclosed adapter with sufficient drain pattern as a heat sink at 50°C ambient.

Note 4. Max. practical continuous power in a open-frame design with sufficient drain pattern as a heat sink at 50°C ambient.

Marking Information
